

CHAPTER 4

WING FIXTURE ASSEMBLY (FB & STD)





REVISIONS

From time to time, revisions to this assembly manual may be deemed necessary. When such revisions are made, you should immediately replace all outdated pages with the revised pages. Discard the out dated pages. Note that on the lower right corner of each page is a "revision date". Initial printings will have the number "0" printed and the printing date. All subsequent revisions will have the revision number followed by the date of that revision. When such revisions are made, a "table of revisions" page will accompany any revision made to a chapter.

Arrows

Most drawings will have arrows to show which direction the parts are facing, unless the drawing itself makes that very obvious. "A/C UP" refers to the direction that would be up if the part were installed in a plane sitting in the upright position. In most cases the part shown will be oriented in the same position as the part itself will be placed during that particular assembly step. However, time goes on and changes are made, so careful attention should be paid to the orientation arrows. That old cartoon of the guy agonizing over the plans for his canoe, built one end up, one end down, should not happen in real life. Especially to you.



	4-1	Chapter 4	REV.	A0/2-01-98	
WING FIXTURE ASSEMBLY (FB & STD)					

CONTENTS

1. INTRODUCTION
2. SPECIAL PARTS, TOOLS, AND SUPPLIES LIST
 - A. PARTS
 - B. TOOLS
 - C. SUPPLIES
3. CONSTRUCTION PROCEDURE
 - A. WORKBENCH CONSTRUCTION
 - B. BUILDING THE FIXTURE
 - C. ALIGNING THE FIXTURE
4. PHOTO PAGES



4-2

Chapter 4

REV. A0/2-01-98

WING FIXTURE ASSEMBLY (FB & STD)



1. INTRODUCTION

This chapter will describe the construction of the fixture that you will need to set the proper dihedral and washout in the wing. Note that this chapter is identical for both fast build and standard kits. Accurate jigs are required to complete both the standard and the fast build versions of the Lancair IV wings.

Since few people happen to have suitable work benches already handy for the fixture construction, we will begin with instructions for the construction of the work benches themselves. It will be possible to build the wings on a bench that is attached to or against the wall, but it will be much easier if you can walk all the way around the benches. After you have constructed the wings, the benches can then be used for the construction of the rest of the aircraft.

The Lancair IV's main spar carry through bolts are pre-drilled at the factory, so the wings do not require a full length jig. Note the suggested layout in figure 4:1. Building one wing at a time will require only one 16' work bench. However, if you have the space, it is easier to build both the wings at the same time. Refer to the "Area Drawing" in the preface, "Wing Removal Area Required" preface and the Figure on page 4-3, titled "Wing Assembly Area Required", and be sure you have adequate room available for the project ahead.

Note: This revised chapter requires cradle drawings, revision B or later.

Wing Cradle Drawings:

- A 101 BL 25.5 Wing Cradle
- A 102 BL 76 Wing Cradle
- A 103 BL 104 Wing Cradle
- A 104 BL 147 Wing Cradle
- A 105 BL 171 Wing Cradle



Wing Assembly Area Required

Figure 4:1

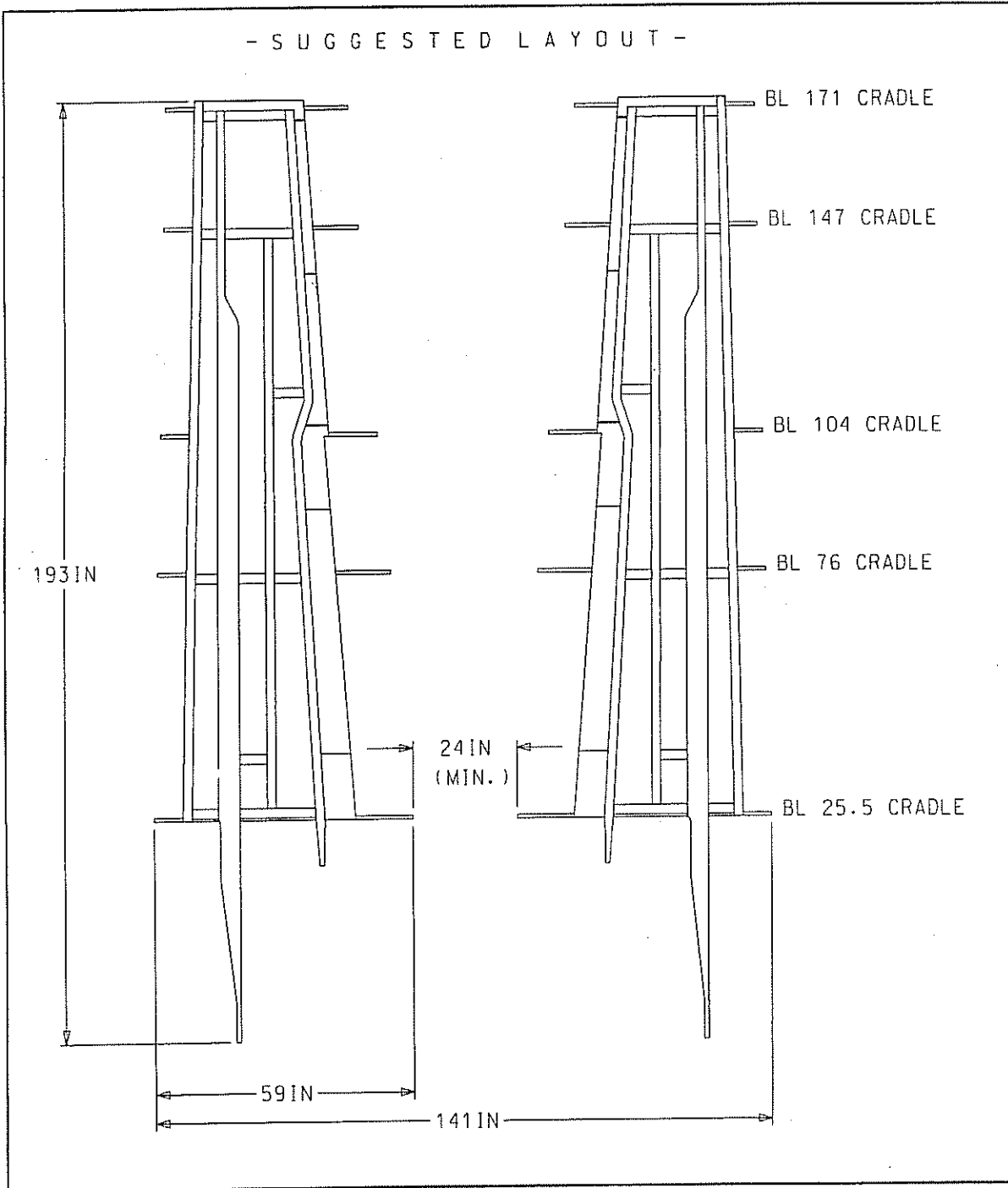

Suggested Cutout for Cradles

Figure 4:2

Note: Precision cut cradles available from Lancair.

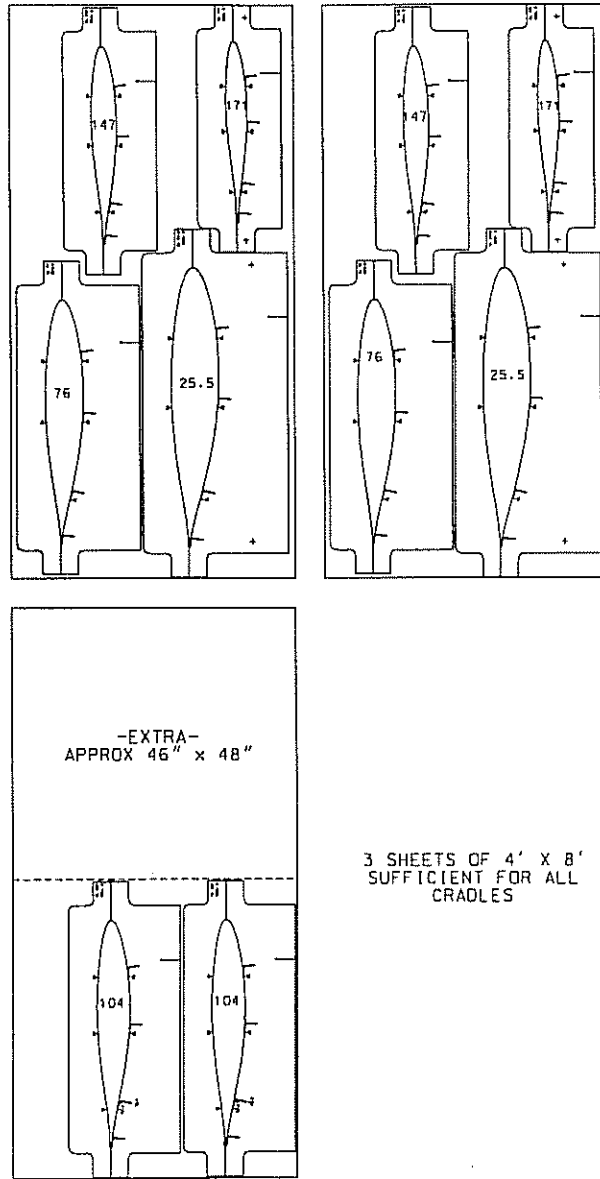

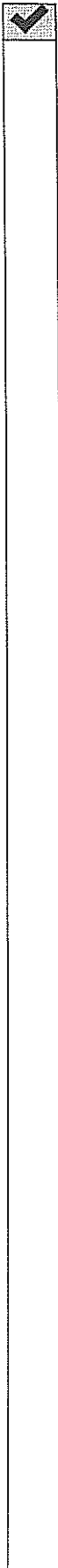

2. SPECIAL PARTS, TOOLS & SUPPLIES LIST

If you do not have the space, or prefer to build one wing at a time, you will need only one sixteen foot fixture, since the five wing cradles for the left wing can be reversed for the right wing.

A. PARTS LIST

Drawing package containing wing cradle drawings.

B. TOOLS REQUIRED

- Hammer
- Screwdriver
- String line
- Carpenter's square
- Table saw, skill saw or ? for cutting plywood
- Chalk liner
- C-clamps, 3", 6 or more
- Plumb bob
- Transit or water level
- Tape measure



C. SUPPLIES

This is a list of the material you will need to construct two 8' work benches and all of the wing supports/cradles:

3 pcs 4' x 8' x 5/8" plywood for wing supports/cradles (enough for left and right side)
2 pcs 4' x 8' x 5/8" plywood for table tops
20 pcs 2" x 4" x 36" for wing support braces
12 pcs 2" x 4" x 29" for table legs*
4 pcs 1" x 8" x 8' for table sides (2" x 4"'s could be used, but the 8" will add more stability)
4 pcs 1" x 8" x 35" for table ends
2 pcs 2" x 4" x 35" for center braces
20 pcs 2" x 4" x 22" for 45 degree leg braces
Spray Mount Artist's Adhesive or similar for temporary paper to wood bonding
Assorted length nails or screws (drywall screws work great, especially with an electric screw driver)
Bondo™ or similar material
1/4-28 all thread for wing cradles
1/4-28 nuts for all thread for wing cradles
-OR- instead of the all thread, use Quick Grip™ Clamps.

DOUBLE THIS LIST IF YOU ARE BUILDING BOTH WINGS AT THE SAME TIME
(except as noted)

*This dimension sets the height of the table top to 29-5/8", and the wing will be up to 20" above the top of the table, so if you prefer to work on a higher or lower table, here is the place to make that change.

NOTE: Later you will need a 13' straight edge (or 2 if you build both wings at once)- a piece of kiln dried wood about 1-1/2" x 2-1/2" is what we use. You might want to pick one up at the lumber yard while you're getting this stuff. Get ones that are as straight as you can find, or have the lumber yard run them through a planer for you. After using the wood as a straight edge, you will build it into the fixtures as a rear spar support. Or you can use 1 1/2" x 2" x 1/8" angle iron.

3. CONSTRUCTION PROCEDURE

A. WORKBENCH CONSTRUCTION

It will probably be easiest to build the table base, level it to the floor in the desired location, and then install the top on it.

Construction Fixture

Figure 4:A:1

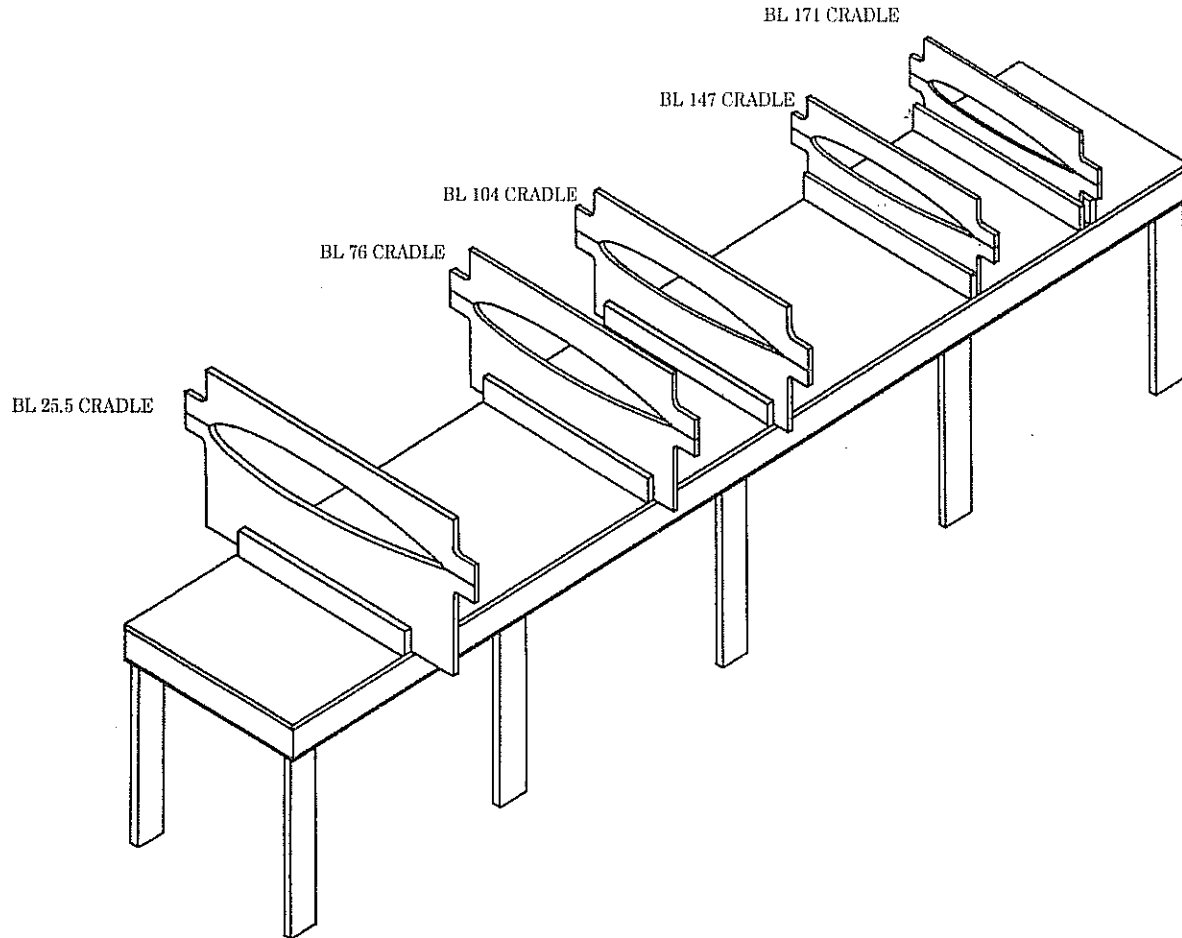

- A1. Take one of the sheets of plywood, select the side you want for a working surface, and lay it on the floor, work surface down.

TABLE BASE ASSEMBLY

Figure 4:A:2

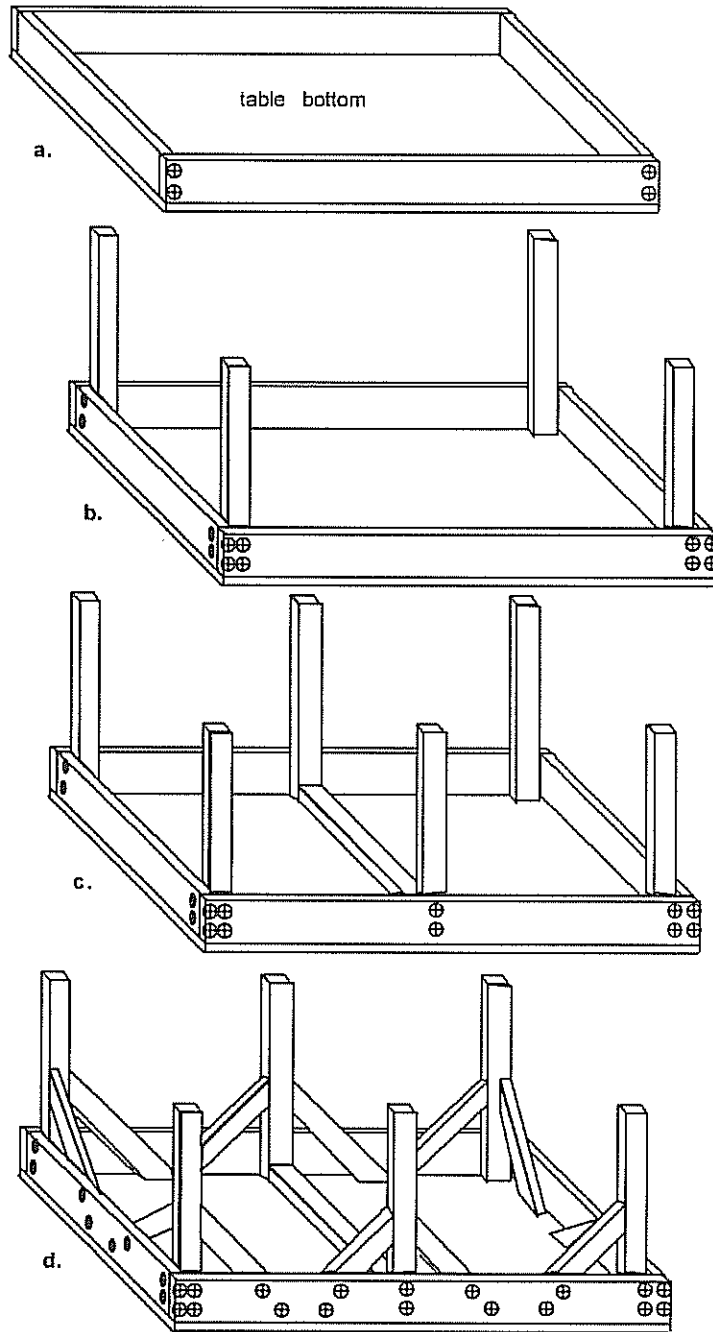

A2. Using a carpenter's square, pick the corner that is "squarest" (it never hurts to check) and mark it as the datum point.



- A3. Measure and mark the plywood for cutting to 36" width, 8' long. (It is OK to leave at 48" wide).
- A4. Cut the plywood to your 3' x 8' marks.
- A5. Form a box on the plywood using two of the 8' table sides and two of the 35" pieces of 8" table ends (which need to be trimmed to fit).
- A6. Screw (you can use nails, but screws give more rigidity) the 8" pieces together, squaring them to the plywood.
- A7. Screw the four corner legs in place (Figure 4:A:2:b), using a level to insure they are vertical.
- A8. Set the two center legs in position, measure and cut the center brace to fit, and screw the legs and brace into position together, as in Figure 4:A:2:c.
- A9. Cut the ends of the 22" pieces off at opposing 45 degree angles and screw into place as shown in Figure 4:A:2:d.
- A10. Turn the base right side up and position it where you will want it. Using sandpaper to shorten and/or tongue depressors or mixing sticks to lengthen the legs, level the table base to the floor.
- A11. Turn the table top right side up and position it on the base, then screw it into place. The level should not change, but check it anyway to be sure, and re-level as necessary.
- A12. Repeat these steps for the rest of the work benches, butting them against each other until you have them all built and level.
- A13. Go underneath the table and screw the table end pieces together in two or three places each (no nails here, use screws - you'll be removing them later) to keep everything rigid while you build the fixture and your wings. You should now have something that looks like Figure 4:A:2.
- A14. As a final step, make any minor levelling adjustments using paper or other material under the legs for shims, and then fix the legs into position on the floor using some Bondo around each one. This will give you a strong, rigid platform that won't be changing shapes on you.

Note: It is not critical to have the tables perfectly level. The goal is to build a sturdy table that will not move when bumped into. The cradles, however, will be perfectly levelled.





B. BUILDING THE FIXTURE

- B1. The wing fixture consists of five wing cradles. Using the spray mount adhesive, paste the Blueprints onto the wing support plywood. Note: Prior to using the print is a good idea to check them. Sometimes there are errors resulting from the blueprinting process such as stretching of the print and "curving."

Checking Blueprints

Figure 4:B:1

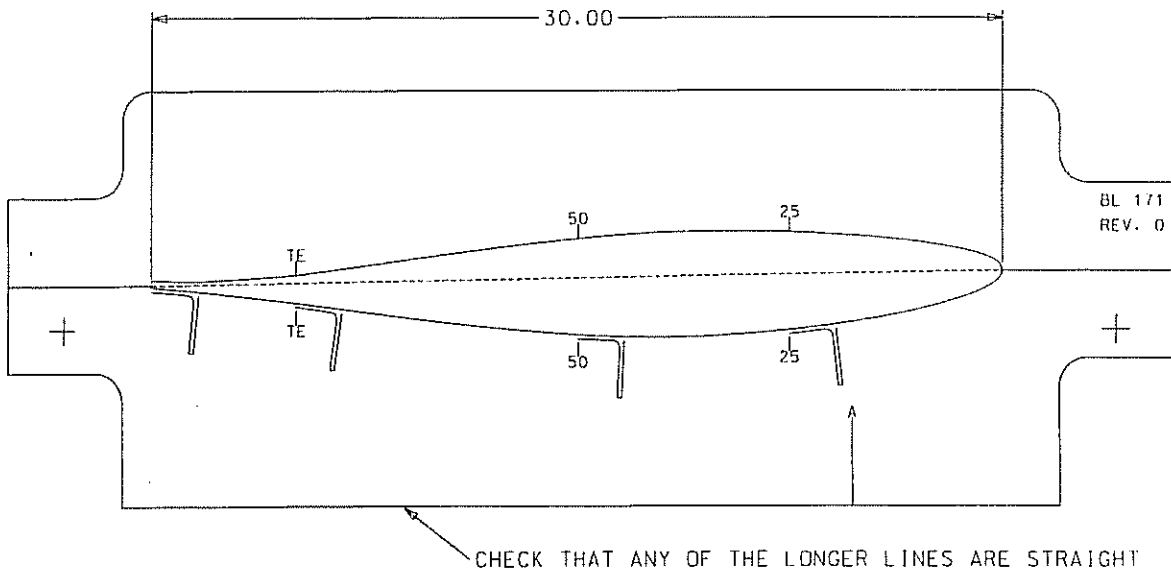

1. Check the scale of the prints as follows:

Measure the chordlength of each of the prints. They should be:

BL 25.5: 47.17" Tolerance: +/-0.1"

BL 76: 41.20" Tolerance: +/-0.1"

BL 104: 37.90" Tolerance: +/-0.1"

BL 147: 32.83" Tolerance: +/-0.1"

BL 171: 30.00" Tolerance: +/-0.1"

2. Check that the prints are straight: Simply pick any long line of the print and check it with a straight edge. There should be no visible curvature.

If you determine that there are inaccuracies with your blueprints contact the parts department for new copies.



Cutting out Wing Cradles

Figure 4:B:2

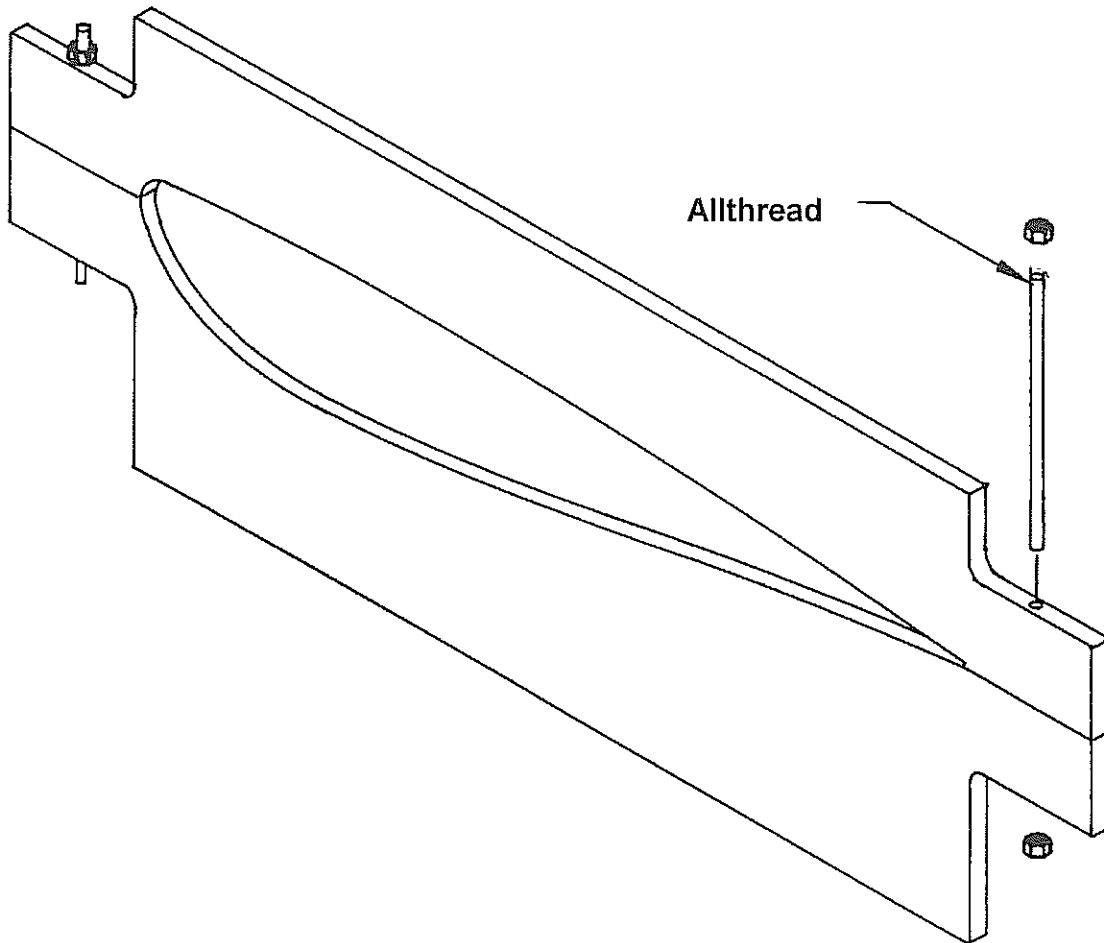

Note: The alternative is to use Quick Grip Clamps or the Equivalent. The jaw opening must be at least 6"

- B2. Using a sabre saw, carefully cut just on the inside of the airfoil shapes. It is important to make a thin cut where the two cradles join. If you make a thick cut, you should compensate for this by gluing a shim to the cradle, such as a tongue depressor. Cut just to the inside of the airfoil outline and then sand up to the line.
- B3. Use sandpaper on the concave shaped cradles that will support the wing to bring the edge out to where you can just see the airfoil line. This will allow the top wing skin to rest on its exact shape. Use care - the accuracy of the cutting and sanding on this fixture will determine if your wing comes out straight or warped.

Fixture Table Layout

Figure 4:B:3

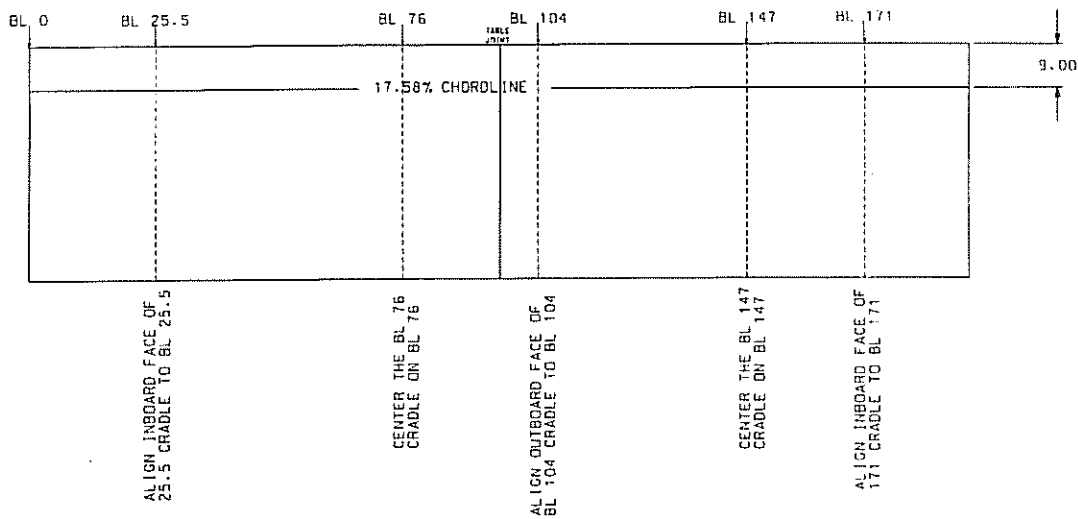

- B4. As shown in Figure 4:B:3, measure 9" in from the long edge of the table at both ends and snap a chalk line between these two points. Using the chalk line as a guide, pencil in a line that won't smudge or blow away. This line will be used to align the 17.58% chord reference for each of the wing cradles.

Wing Planform:

With a fully tapered wing, neither the L.E. nor the T.E. of the wing are parallel nor perpendicular to the fuselage centerline. With each rib, 17.58% of the rib's length (chord length) will reference a common alignment point when measured aft from the rib's L.E.

These 17.58% of chord points, on all wing ribs, will line up together spanwise, and will be perpendicular to the fuselage centerline. Refer to drawing 4:B:4.

Planform Drawing

Figure 4:B:4

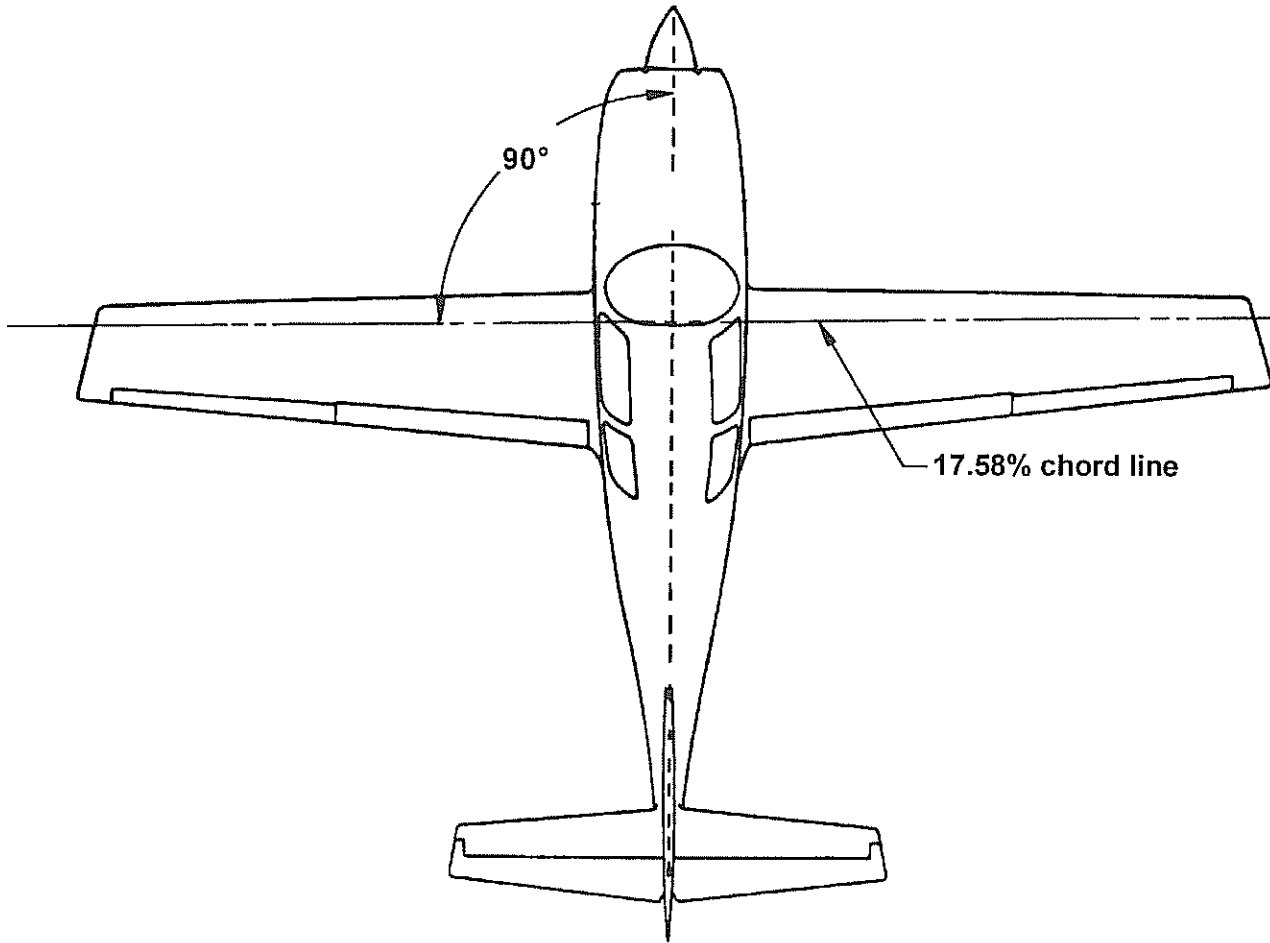

- B5. Measure along the line from the datum end of the table (if using only a 16' table) or from the middle of the table outward in both directions (if using a 32' table) and mark the BL 25.5, BL 76, BL 104, BL 147 and BL 171 positions. Using your square and straight edge, extend these lines across the width of the table. It is also a good idea to make a mark every inch along the BL. BL 0 will be located at the datum point on the work bench.
- B6. Using you carpenter's square as shown in Figure 4:B:5, install a wing cradle brace at the BL 25.5 position, at a right angle to the chord line, so that when the wing cradle is put in place it will have its inboard edge, not its center, on the BL 25.5 line.

LANCAIR® IV

4-14

Chapter 4

REV.

A0/2-01-98

WING FIXTURE ASSEMBLY (FB & STD)

Installing Wing Cradle Brace

Figure 4:B:5

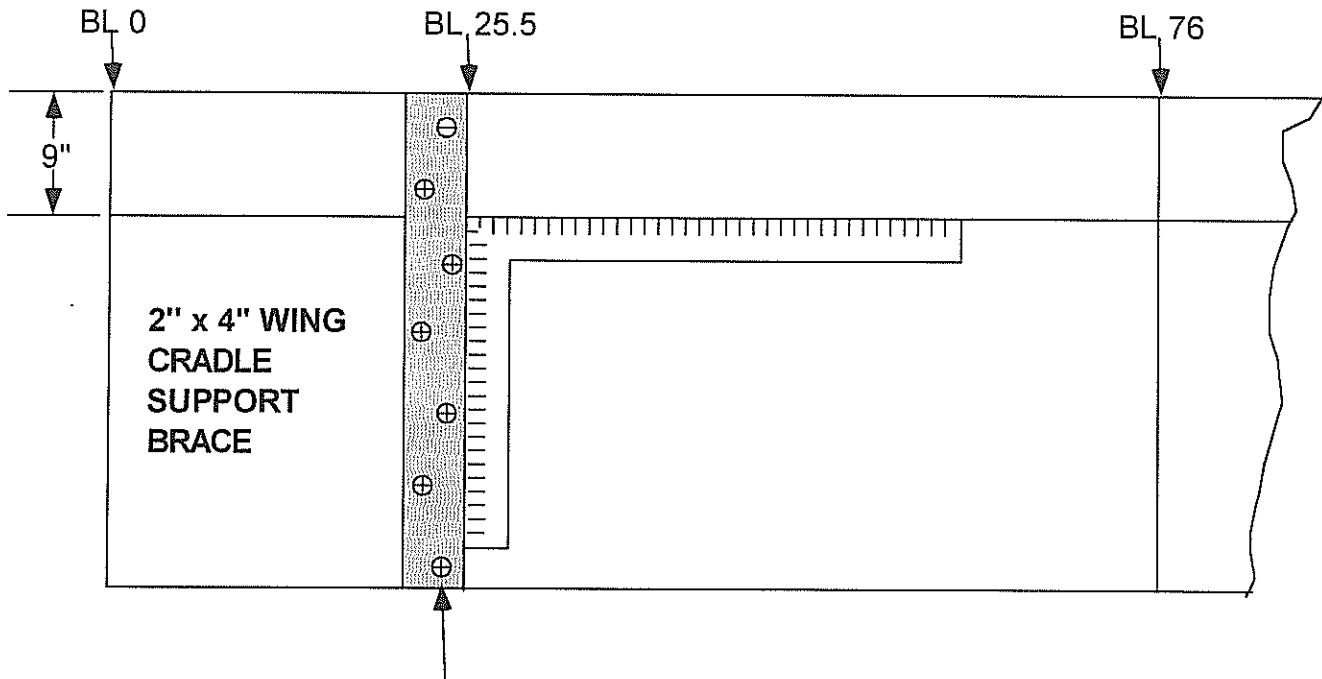

Screws may be installed from the top or underside of the table.

- B7. Repeat this process for the BL 76, BL104, BL 147 and BL 171 braces, installing one brace at each location. The BL 171 cradle must be mounted so its inboard edge is on the BL 171 mark. The BL 104 cradle must be located so that its outboard edge is on BL 104 cradle. Adjust the brace as necessary. The BL 76 and BL 147 cradles can be centered on their BL marks, they aren't that critical.



C. ALIGNING THE FIXTURE

On the Lancair IV cradles there are several reference marks. Using these reference marks (the cross hairs on the inboard and outboard cradles) as outlined in these instructions, sets the washout. The dihedral is already set (the spars are pre-drilled).

Summary of Leveling Procedure (Steps 1 & 2 is for reference only. We suggest you read the entire section)

1. Align inboard and outboard cradles:

- The inboard and outboard cradles are aligned using the 17.58% reference line to the line you drew on the table.
- Use the leveling reference marks (the cross-hairs) to level the cradles. Level the cradles such that the cross hairs are in the same level and horizontal plane.

Inboard Outboard Alignment of all Cradles:

BL 25.5 cradle: Inboard face of cradle aligned to BL 25.5

BL 76 cradle: Centered on BL 76

BL 104 cradle: Outboard face of cradle aligned to BL 104

BL 147 cradle: Centered on BL 147

BL 171 cradle: Inboard face of cradle aligned to BL 171

2. Align cradles at BL 76, BL 104, and BL 147.

- The remainder cradles are aligned using a string line to align to the inboard and outboard cradles.

LANCAIR[®] IV

4-16

Chapter 4

REV.

A0/2-01-98

WING FIXTURE ASSEMBLY (FB & STD)



Wing Cradle Alignment Procedure.

Typical Wing Cradle

Figure 4:C:1

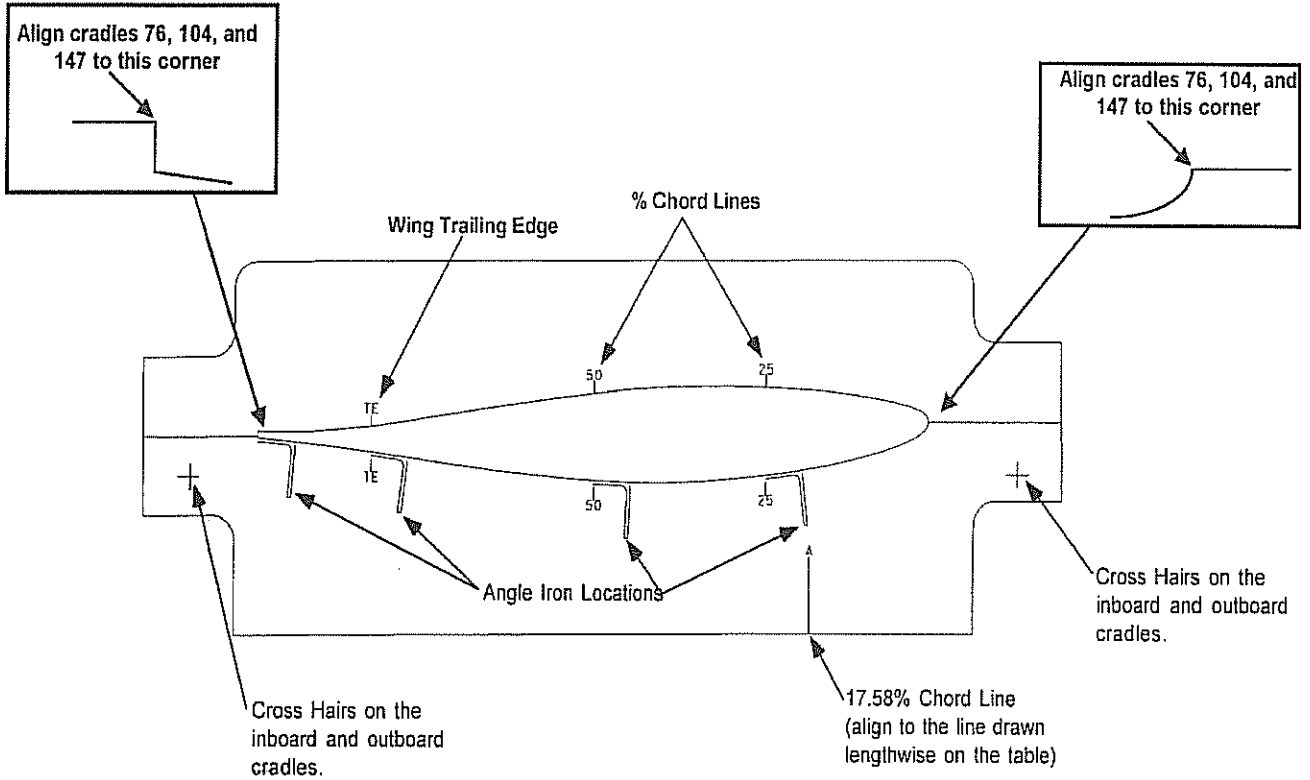

Aligning Inboard and Outboard Cradles

Figure 4:C:2

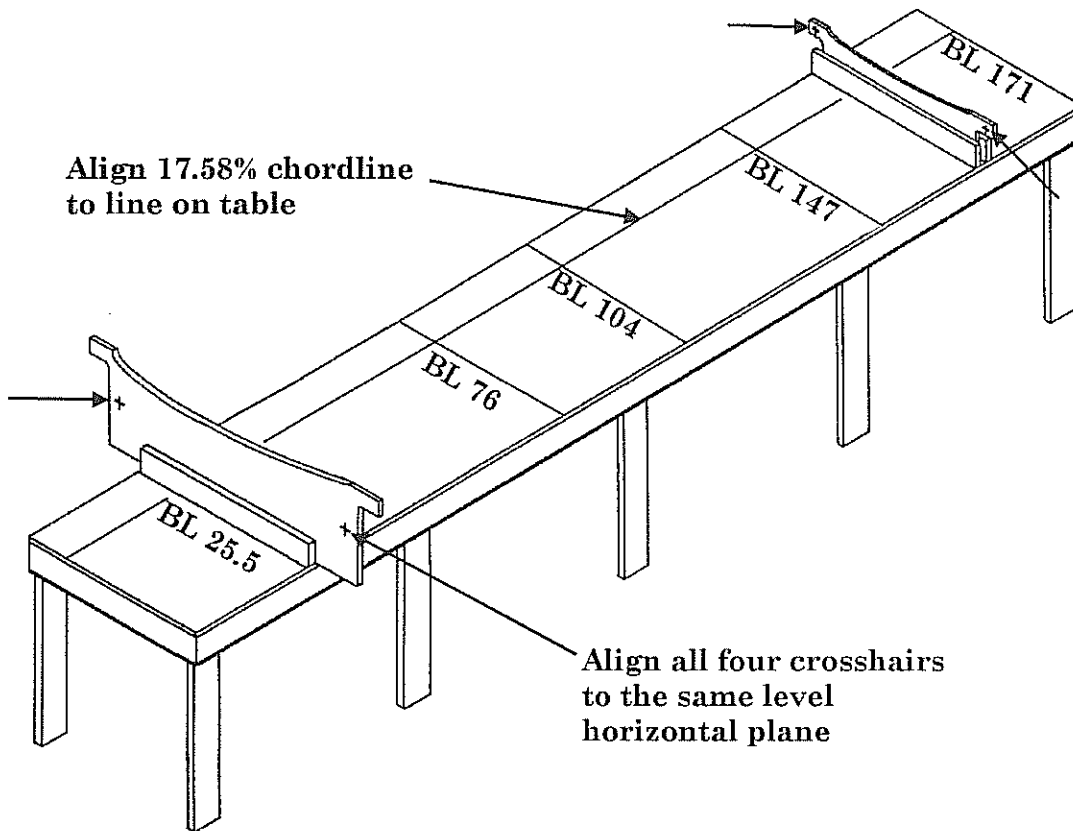

- C1. Using C clamps to hold the bottoms of the cradles temporarily in place (since we haven't yet determined their exact height), clamp the BL 25.5 and the BL 171 cradles to their respective braces (being sure to have their inboard edges on the BL marks and, using the 17.58% chordline mark on the cradle and a plumb bob, line the cradle 17.58% chordline up directly over the chalk line you made 9" from the edge of the table).

The two criteria for aligning the BL 25.5 cradle and BL 171 cradles are:

- 1) The BL 25.5 cradle's inboard face should align to BL 25.5 and the BL 171 cradle inboard face should align to BL 171.
- 2) The 17.58% chordline should align to the line on your table.
- 3) The 4 cross-hairs should be in the same level horizontal plane.

Hint: When starting the alignment process, it is helpful to have a gap between the bottom of the cradle and the table. Use shims such as approx. 5 tongue depressors stacked. This allows you to move the cradle *down* if the alignment process dictates such.

LANCAIR® IV

4-18

Chapter 4

REV.

A0/2-01-98

WING FIXTURE ASSEMBLY (FB & STD)

Aligning BL 76, BL 104, and BL 147.

Figure 4:C:3

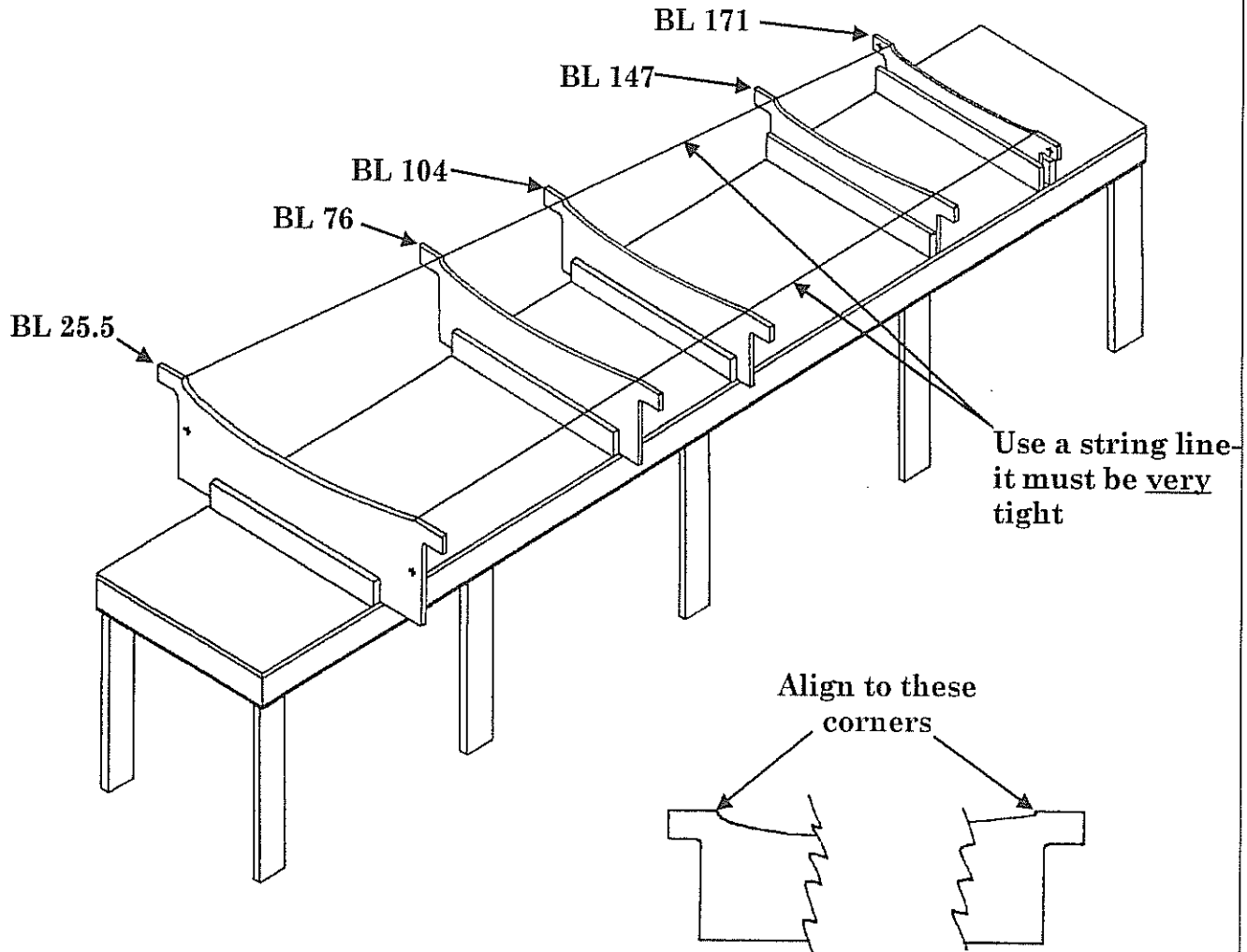

- C2. The remainder cradles are aligned to the BL 25.5 and BL 171 cradles by using a string. It is important that the strings are tight. Bring the cradles up to the string so they are just touching. By using this technique, it is possible to achieve a high degree of accuracy.
- C3. Eventually we will have a considerable amount of weight on the braces, and they must not move under that load. Place the second brace on the table, tight against the cradle, and screw it to the table. Refer to Figure 4:C:4.

Installing the Second Cradle Brace

Figure 4:C:4

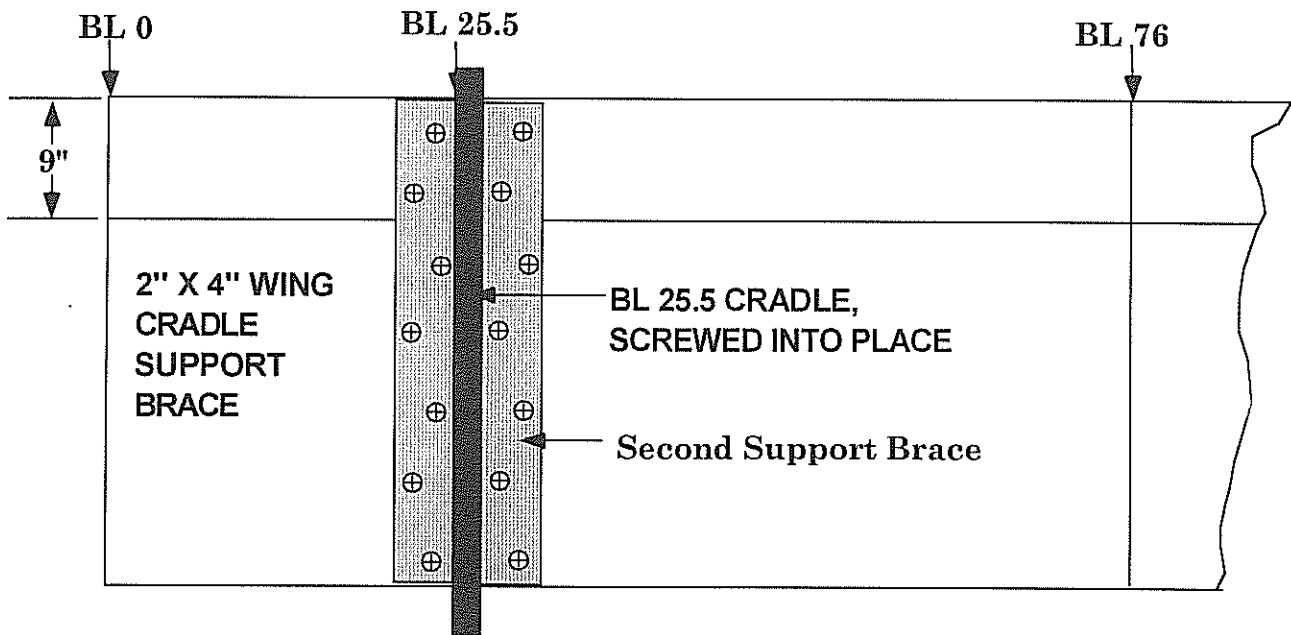

- C4. Using a level or a plumb bob, make sure the cradle is perfectly vertical, and run three or four screws through one brace, the cradle and into the other brace to hold everything tight, true and vertical. Recheck everything after the screws are in place, just to make sure.

Notches for Angle Iron

Figure 4:C:5

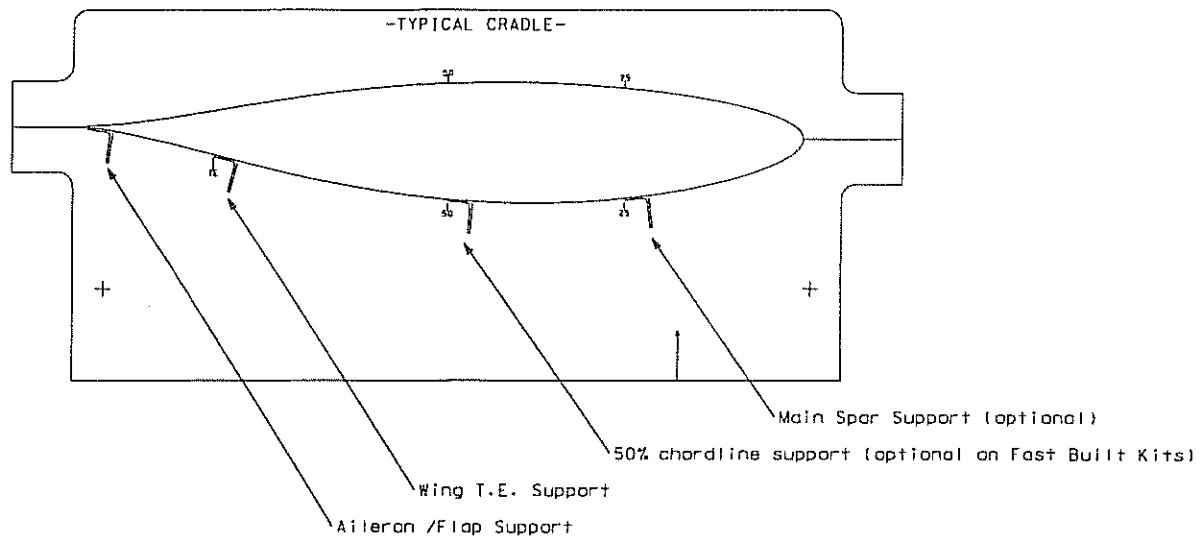

The precision cut cradles available through Lancair have notches cut out for the angle iron. The notches are for 1 1/2" x 2" x 1/8" angle iron (This is approx. 3.8 cm x 5.1 cm x 3 mm). If this is not available, modify cradles as necessary. It is also an option to purchase kiln dried wood such as 1 1/2" x 2 1/2" stock.

Aileron Support at BL 104

Figure 4:C:5

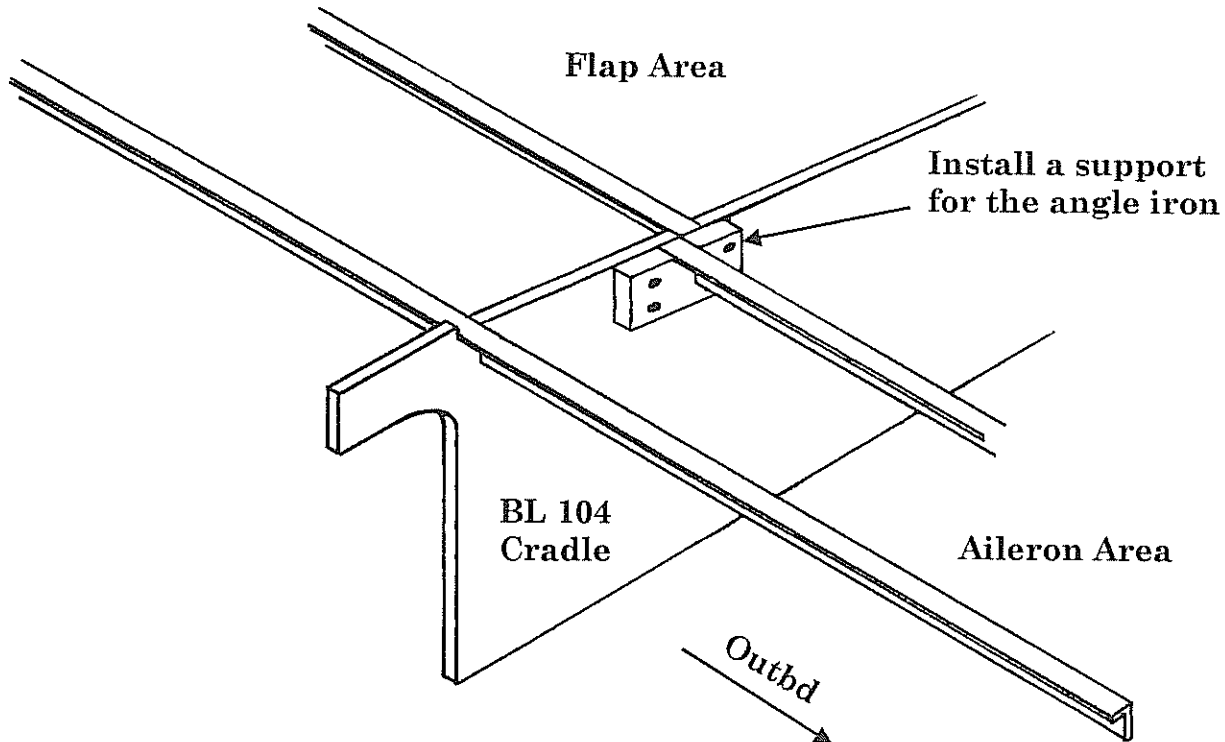

- C5. Note that the cut in the T.E. in the BL 104 cradle is for the flaps. It is necessary to make a support for the T.E. of the ailerons. We suggest, a piece of plywood cut to accept the angle iron. Align to the mark for the T.E. of aileron.

4. PHOTO PAGES

